

Adjustable Cooling Fins Shown

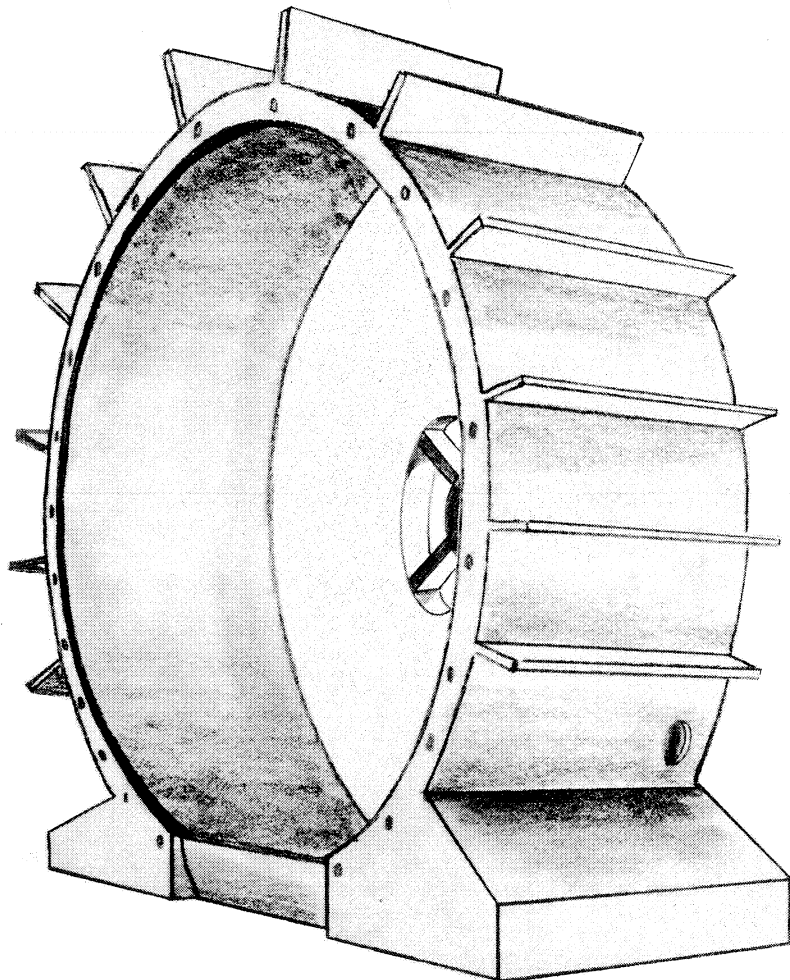

Exhibit 1. Start with Basic construction shell

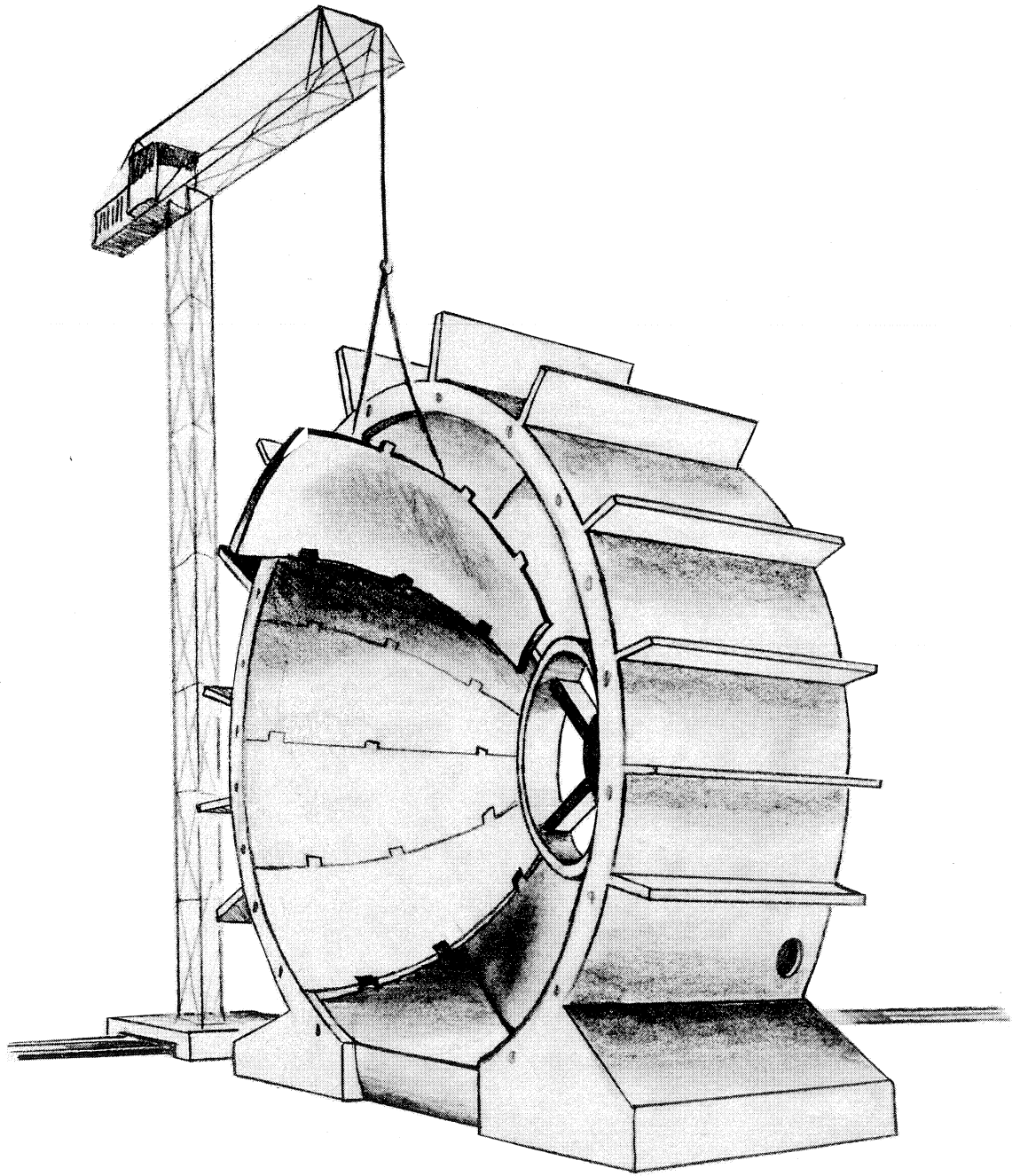

Exhibit 2. Install Basic Exhaust Deflector

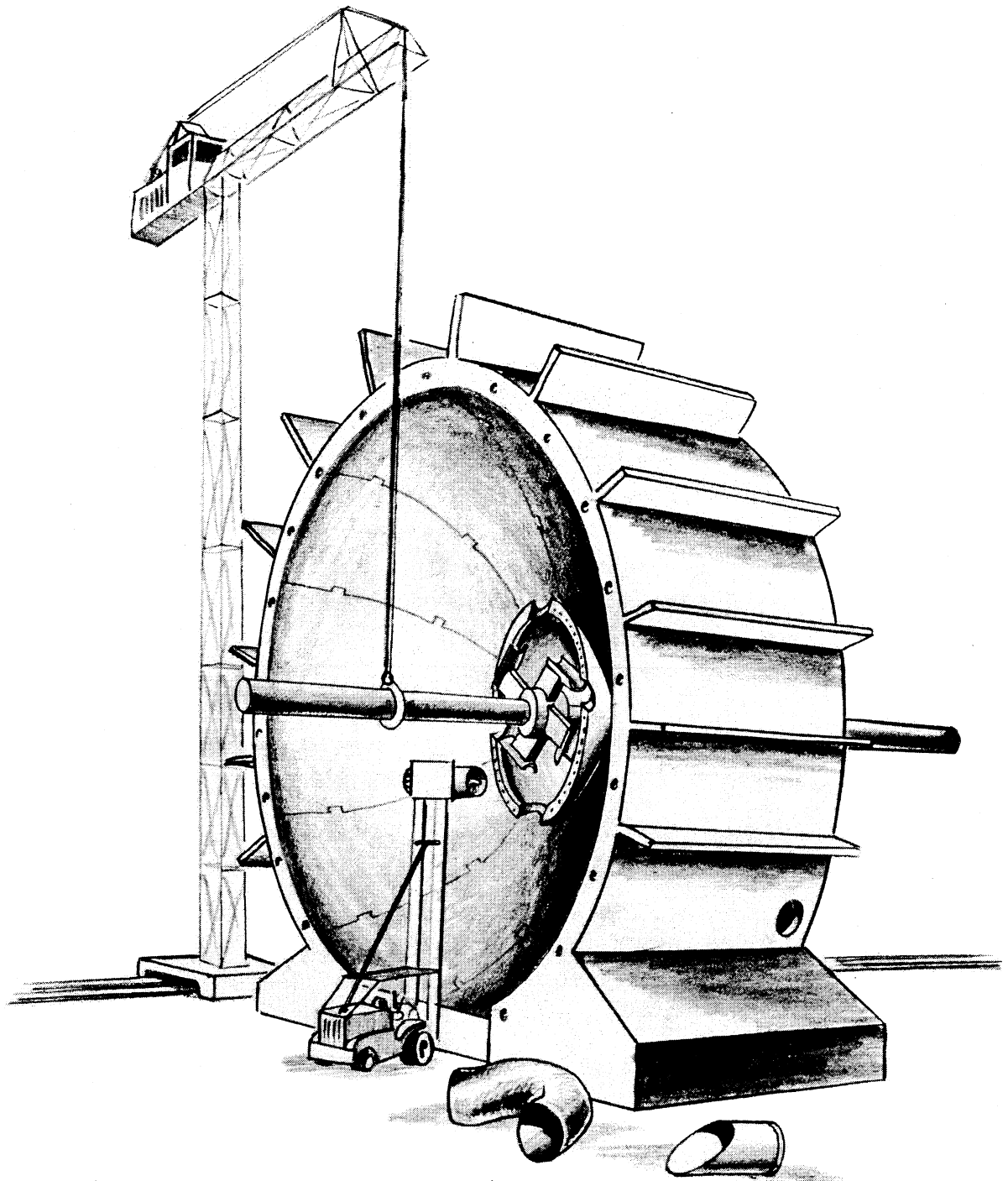

Exhibit 3. Install shaft, Front side of Aerodynamic Shell and Engine mounts.

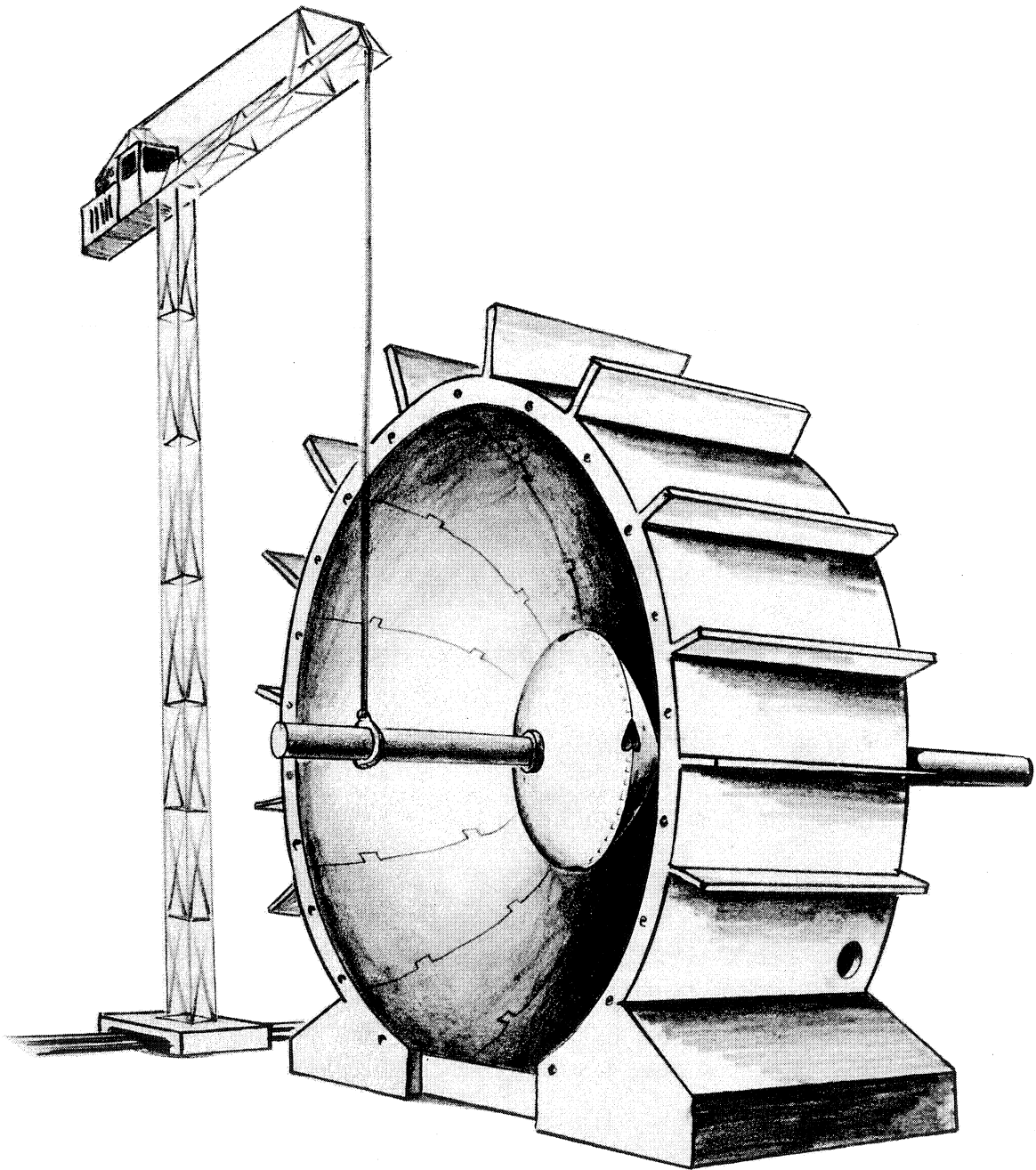
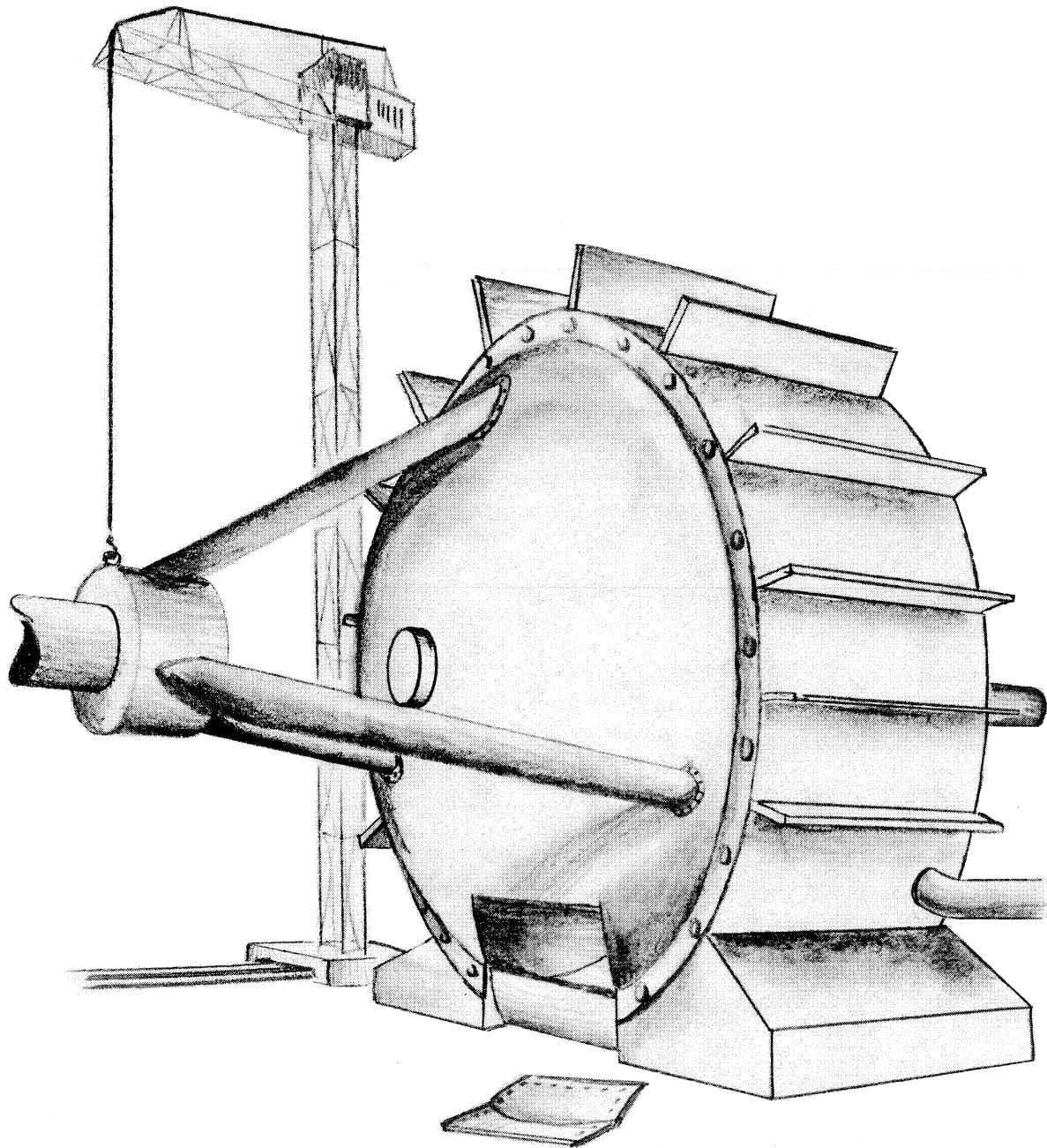
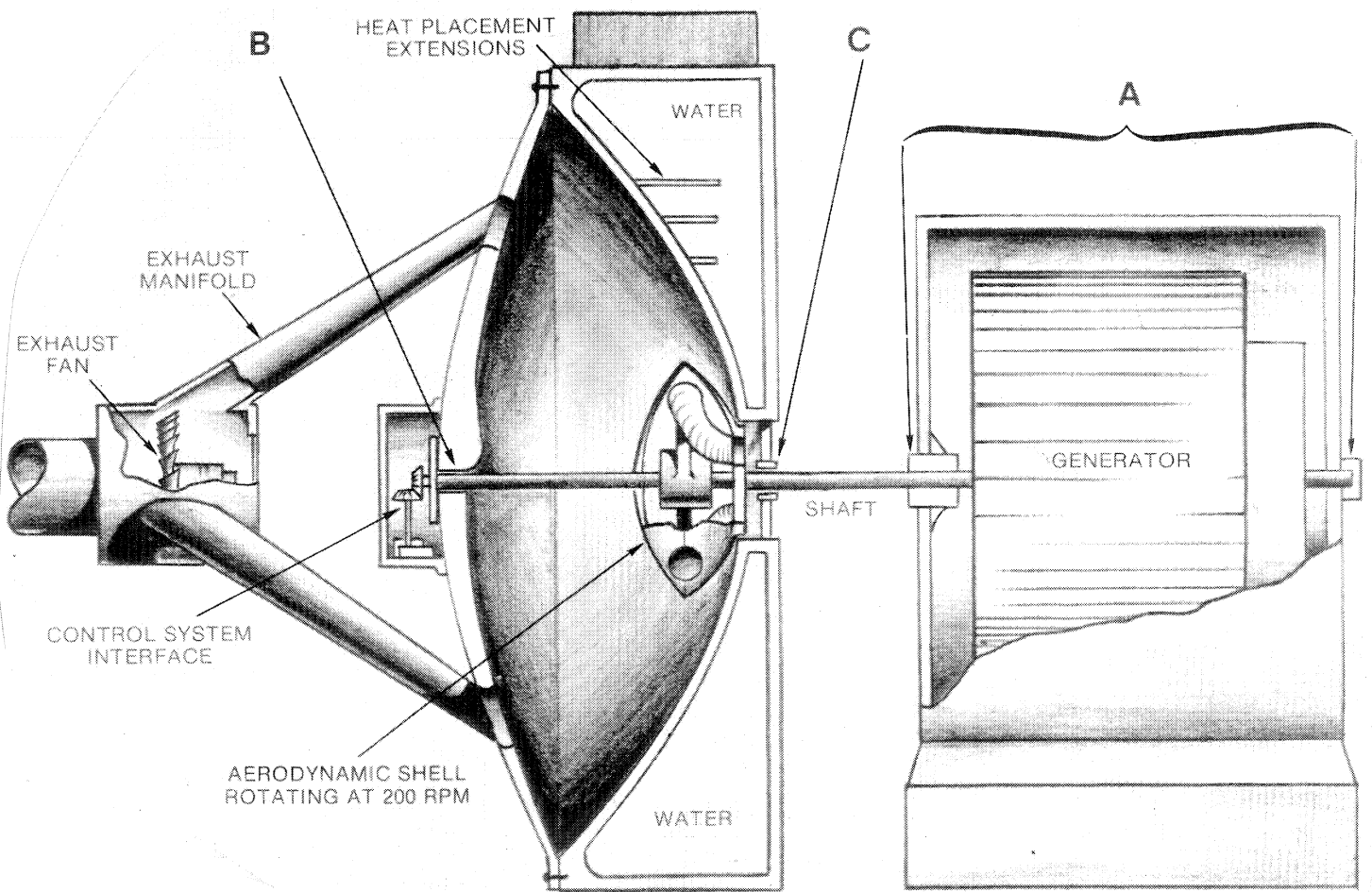

Exhibit 4. Install Rear Side of Aerodynamic Shell.

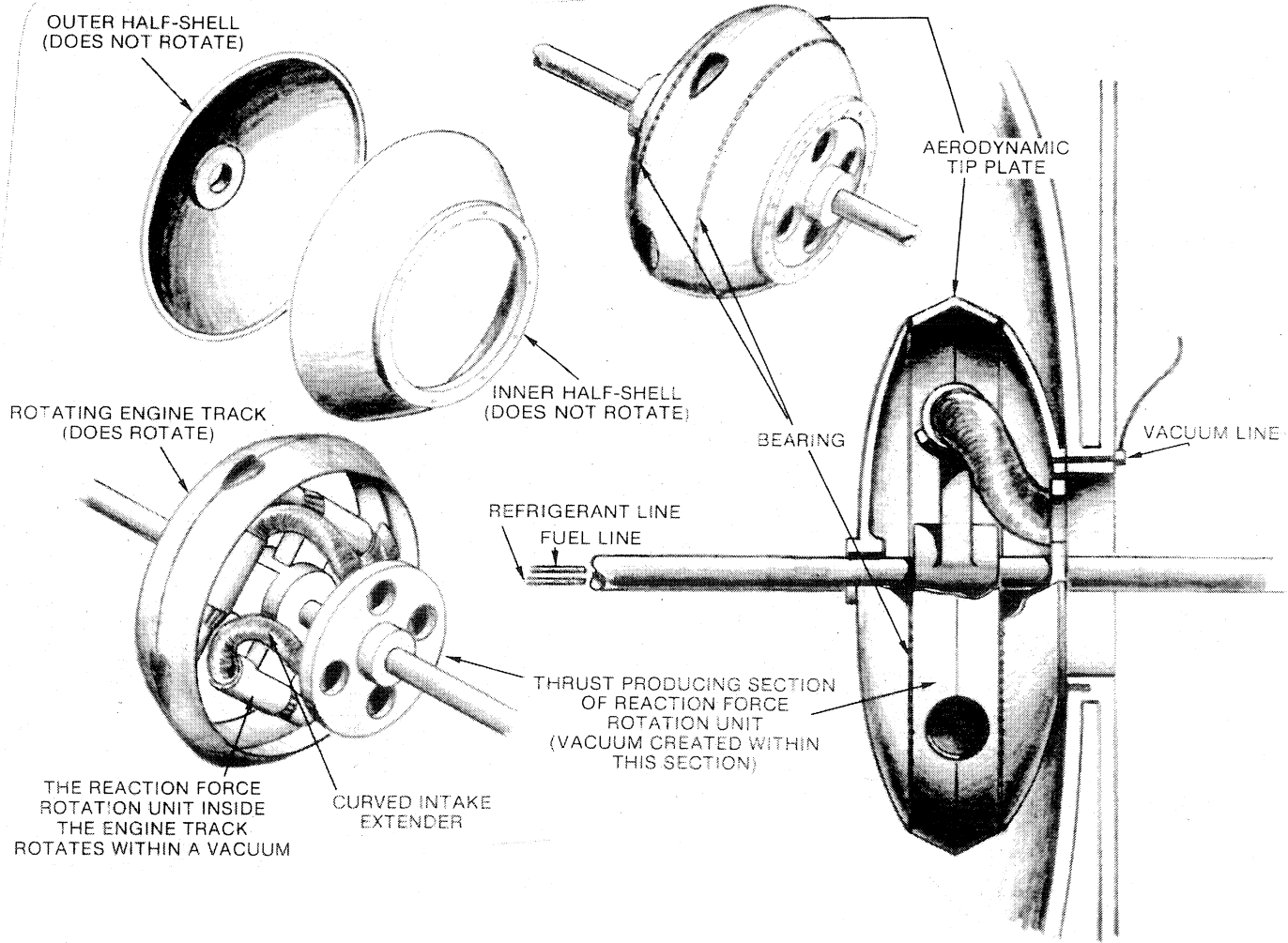

**Exhibit 5. Install Rear Cover, Exhaust Manifold
And control System.**



**The Thrust Architecture
And
Multi - Pole Generator**

Reaction Force Rotation Unit



Engine Replacement / Removal

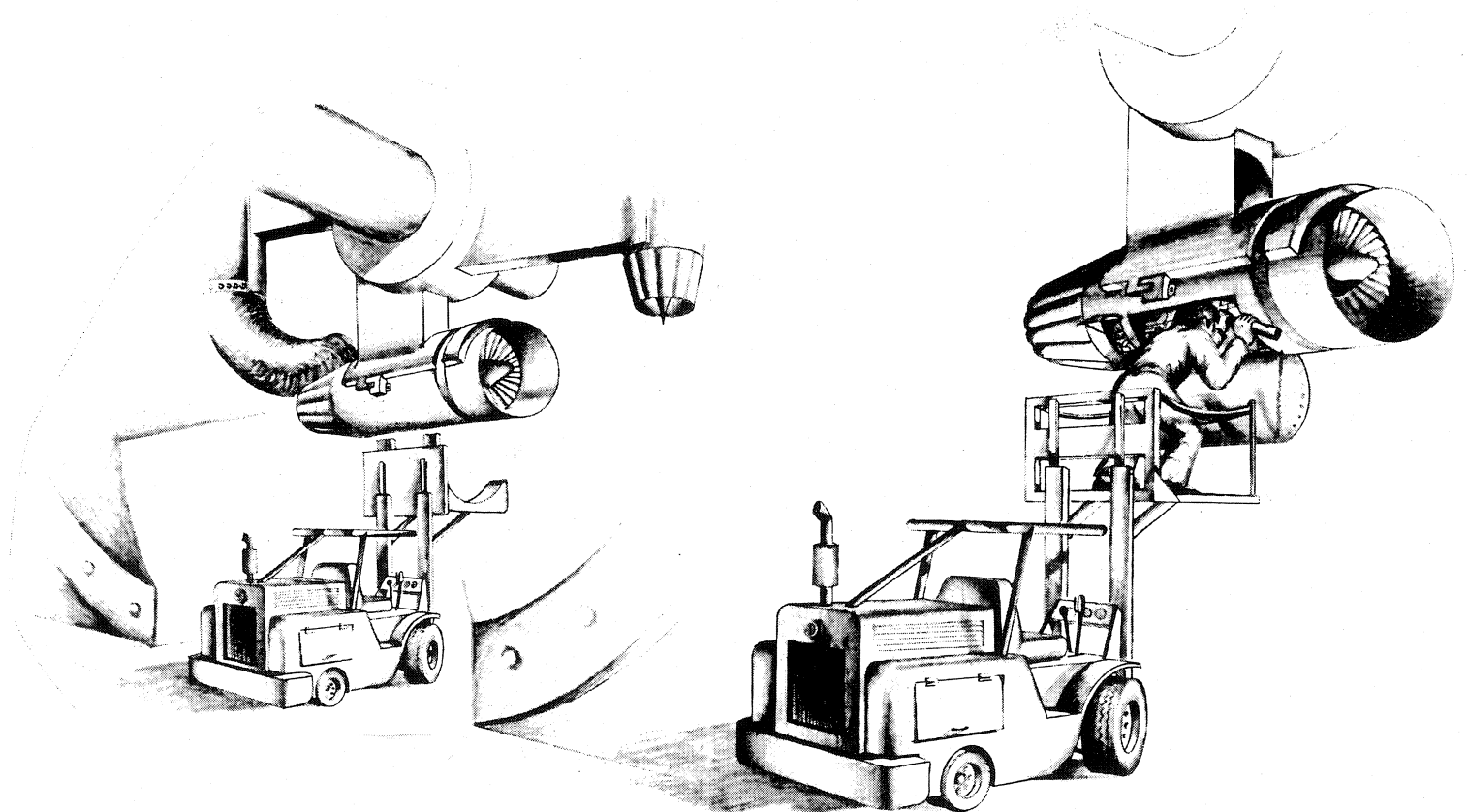

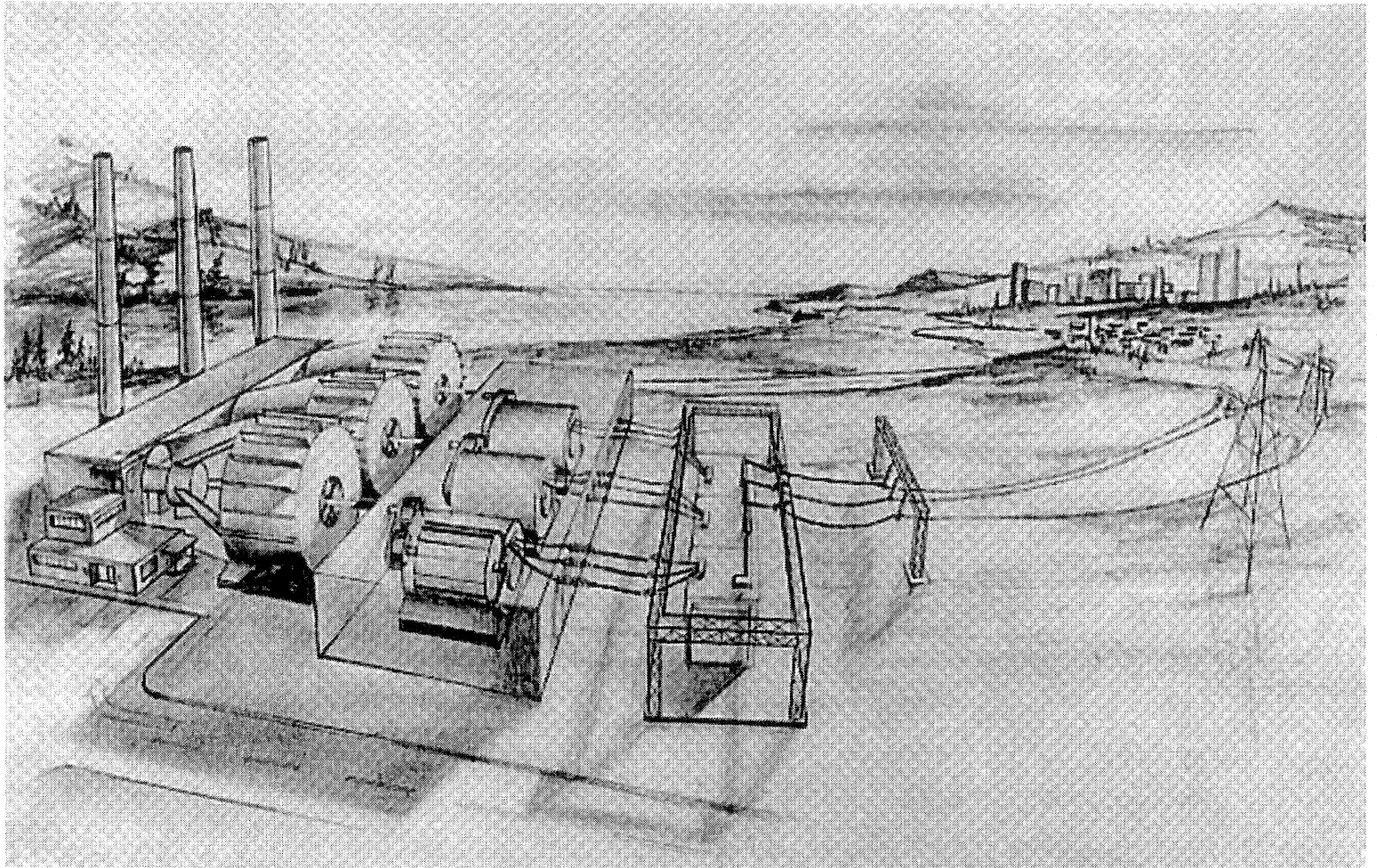

**Artist Concept of Three Unit System
(Controlled Air Chamber Not Shown)**